



106IM™

DIRECT WEATHER HIGH PERFORMANCE LOUDSPEAKER SYSTEM

ONE SYSTEMS®

The One Systems 106IM was designed to provide high acoustic output and IP 56-rated direct-weather performance for a variety of acoustic spaces. The 106IM is a very high-performance background / foreground speaker system designed for use in all weather conditions. The 106IM is available in black and white finishes and can also be painted to match décor-critical applications.

The 106IM's design is very unique for a system of this size in that it utilizes a true compression driver coupled to a constant-directivity horn. The driver/horn's coverage pattern is 100 degrees horizontal by 70 degrees vertical. The high efficiency compression driver and its advanced crossover design provide very high power handling and excellent system reliability without the need for performance-degrading passive protection devices typically found in loudspeaker systems in this class. The 6-inch (152 mm) high-performance woofer is equipped with an extra-large 1.75-inch (44.33 mm) voice coil that delivers extended bandwidth response and superior low-frequency power handling. The 106IM's combination of the high-efficiency horn-loaded compression driver and very large-format voice coil design in the woofer yields superior system intelligibility, vocal range integrity and added musical definition.

The 106IM's enclosure is injection-molded utilizing a copolymer material designed for use in extreme harsh weather environments that also offers a high degree of UV protection for use in direct sunlight. The enclosure has 7 mounting points including 3 x M6 points on the top and bottom of the enclosure for use with the supplied 106IM-U U-Bracket. There are also 4 x M5 mounting points on the rear of the enclosure for use with the optional PT-10 pan and tilt bracket. There is also an optional pole-mount kit called Pole Mount Mini which includes the PT-10.

All 106IM's mounting points are made of stainless steel. The grille's assembly is a 3-layer design that is optimized for both acoustic transparency as well as protection from windblown particles and water. The input section features a weather cover with an integral gland nut that is rated to an IP 68 standard. The system's input connectors are a four-position barrier strip.

The 106IM is available in both an 8-ohm impedance as well as 70.7-volt and 100-volt versions. The optional transformer versions feature wide-bandwidth transformers with 50-watt, 25-watt and 12.5-watt taps that are accessible through the system's four-position barrier strip. The 106IM's power handling is 100 watts continuous, 200 watts program and 400 watts peak.

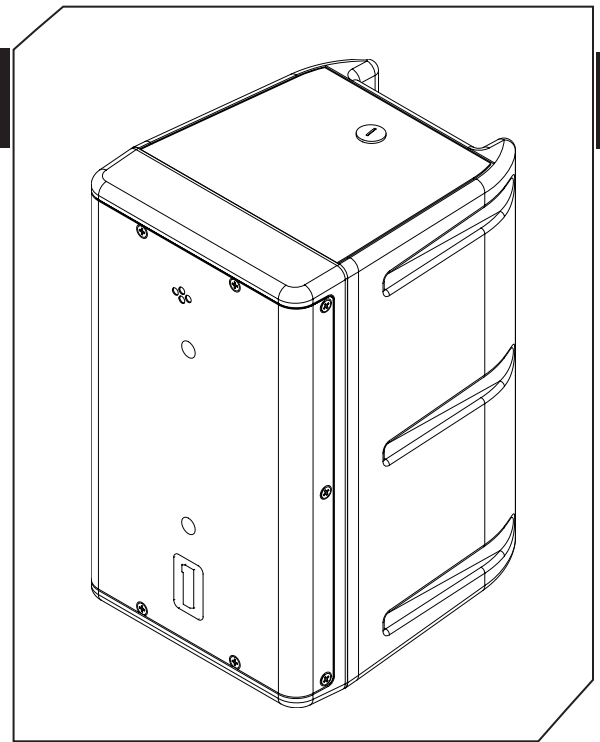

FEATURES & BENEFITS

- » Direct-weather capable, compact 6-inch two-way system
- » 6-inch woofer with large-sized 1.75-inch voice coil
- » Medium-format compression driver with 100° x 70° constant-directivity horn
- » Available in black or white, 8-ohm or transformer-coupled versions
- » U-Bracket included
- » No performance-degrading passive protection devices necessary
- » Stainless steel grille, suspension and rigging hardware
- » 100 watts continuous, 400 watts peak power handling

SPECIFICATIONS

Frequency Response:	80 – 16,000 Hz
Coverage Pattern:	100° H x 70° V
Crossover Frequency:	2,000 Hz
System Sensitivity (1watt / 1meter):	89 dB
Power Handling:	100 watts continuous, 200 watts program, 400 watts peak*
Optional Transformer Taps:	12.5 watts, 25 watts, 50 watts
Nominal Impedance:	8 ohms
Weather Performance:	IP56



106IM™

DIRECT WEATHER HIGH PERFORMANCE
LOUDSPEAKER SYSTEM

ONESYSTEMS®

SPECIFICATIONS (continued)

Dimensions (H x W x D) mm: 312 x 185 x 217.1

Dimensions (H x W x D) in: 12.3 x 7.3 x 8.5

Net Weight (kg lb): 6.0 kg / 13.2 lb.

70.7 / 100V Versions: 6.5 kg / 14.3 lb

Shipping Weight: 8.6 kg / 18.92 lb.

70.7 / 100 V Versions: 9.2 kg / 20.24 lb

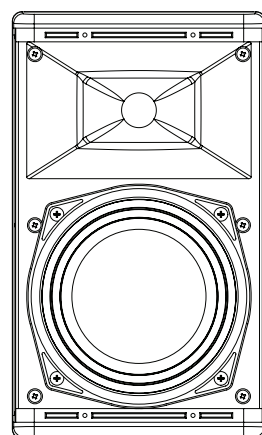
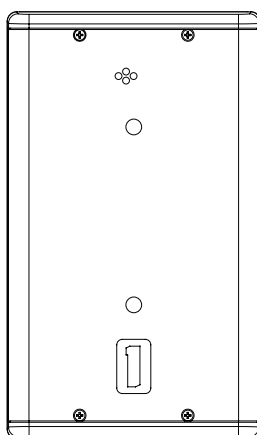
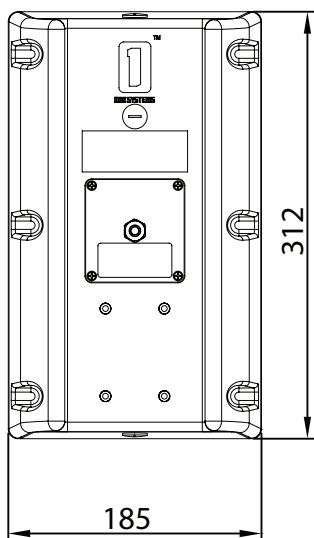
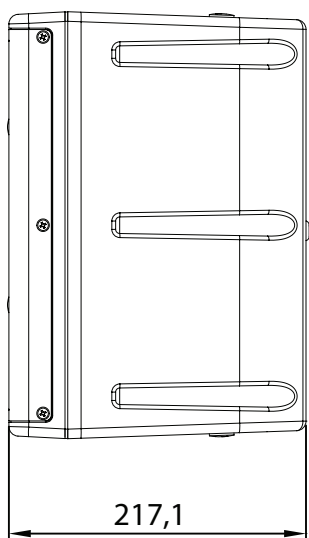
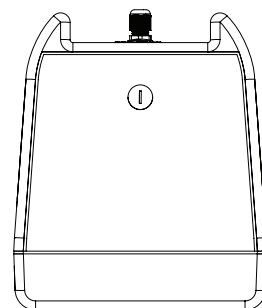
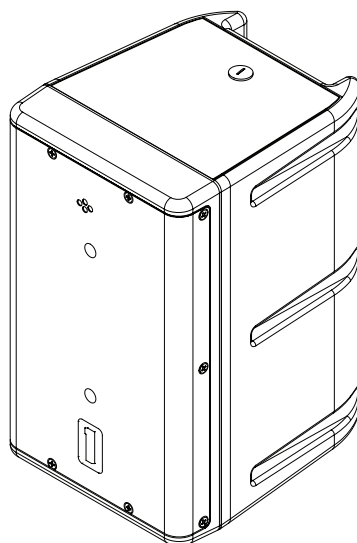
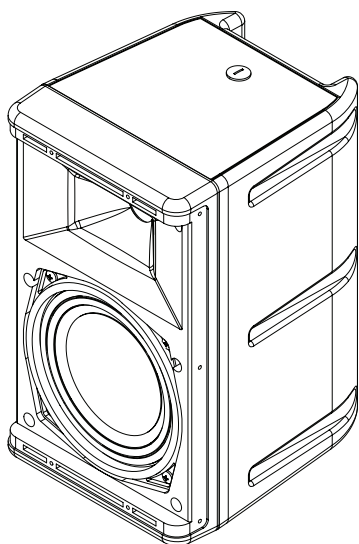

ONESYSTEMS®

One Systems, Inc • 6204 Gardendale Dr. • Nashville, TN 37215

One Systems Global Co. Ltd. • 87/114 Modern Town 15th Floor • Sukhumvit 63 Ekkamai Soi 3
Klongtoey, Bangkok 10110 Thailand